

713-52 mifare® ID Reader Module

Data Sheet

Overview

The 713-52 Mifare reader module is a fully-encapsulated device containing all the electronics required to read the unique ID from a mifare® card and output the code in one of many user selectable formats. An external antenna is required.

Specifications

- Power requirements: 5 - 13.8V dc. Current consumption is 90 mA during normal operation, 10mA when in SHUTDOWN mode, and 80mA while in INHIBIT mode.
- RF Frequency: 13.56 MHz.
- Card types supported: mifare® Std cards with 4-byte ID.
- Contactless interface as per specification: ISO/IEC 14443 Type A.
- Output formats supported: Wiegand (44-bit, 34-bit, and 26-bit), Mag Stripe emulation, Clock/Data, RS232 (9600,n,8,1) TTL levels
- Typical reading range: 75mm (dependent on the area of the antenna).
- Operating temperature range: -20°C - +60°C.
- Weight: <30 grams.

Pinout Description & Dimensions

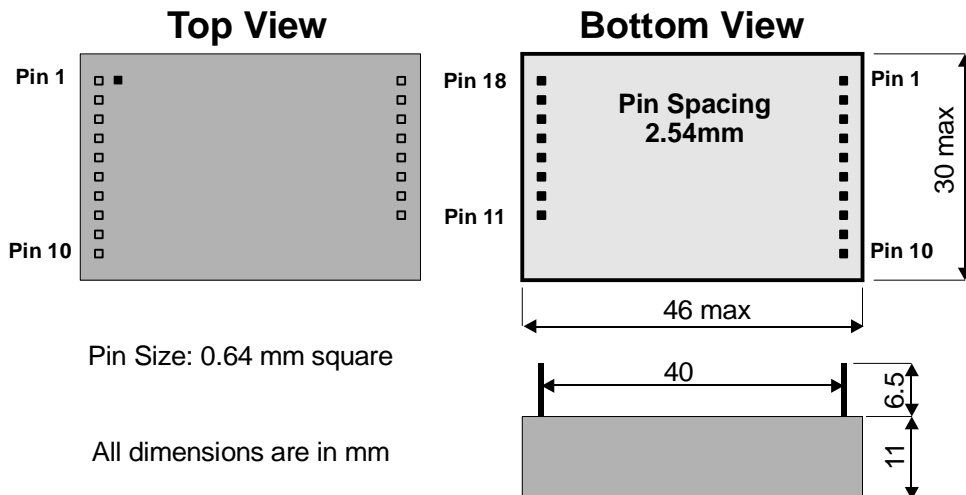

Pin #	Pin name	Function
1	DETECT	Pulses low when an RFID tag is detected. It stays low while the module output is active.
2	CLOCK/DATA0	Outputs RFID tag code in selected format.
3	DATA/DATA1	Outputs RFID tag code in selected format.
4	Reserved	Leave disconnected.
5	INVERT	Connect this pin to 0V to invert output on pins 1,2,3.
6	SELECT1	The user can connect to 0V or leave disconnected to select different output formats.
7	SELECT2	
8	SELECT3	
9	SELECT4	
10	Reserved	Leave disconnected.
11	ANTENNA GND	Connect to outer conductor of 50ohm antenna coax.
12	ANTENNA SIG	Connect to inner conductor of 50ohm antenna coax.
13	ANTENNA GND	Connect to outer conductor of 50ohm antenna coax.
14	RAW DATA	Outputs the raw data stream detected from the tag.
15	BEEPER	Open collector output for connection to an external beeper.
16	SHUTDOWN	Input - pull high to shutdown module.
17	SUPPLY VOLTAGE	Connect +5V - +13.8V from power supply.
18	0V	Connect 0V from power supply.

Output Mode Selection

The module has four mode selection pins (SELECT1 ... SELECT4). These pins are internally pulled high in the module. To select the different modes the SELECT pins may be tied to 0V (indicated as 0) or left unconnected (indicated as 1) according to the following table:

SELECT4	SELECT3	SELECT2	SELECT1	Output Mode
0	0	0	0	Inhibit - turn off RF field
0	0	0	1	RS232 - 24 bit
0	0	1	0	RS232 - 32 bit
0	0	1	1	RS232 - 40 bit
0	1	0	0	Tune - continuous reading
0	1	0	1	<i>Unused</i>
0	1	1	0	<i>Unused</i>
0	1	1	1	<i>Unused</i>
1	0	0	0	Fast Mag Stripe - 40 bit
1	0	0	1	Mag Stripe - 24 bit
1	0	1	0	Mag Stripe - 32 bit
1	0	1	1	Mag Stripe - 40 bit
1	1	0	0	Basic Clock/Data
1	1	0	1	Wiegand - 26 bit
1	1	1	0	Wiegand - 34 bit
1	1	1	1	Wiegand - 44 bit

Power Considerations

If less than 5.5V is supplied to the module this voltage should be regulated. Read range will drop by 10% when the supply voltage is below 5.5V.

External Beeper Connection

The module pin 15 (BEEPER) is an open collector output. It outputs a frequency of 4 kHz for 60 ms when a tag is read. Two typical circuits are:

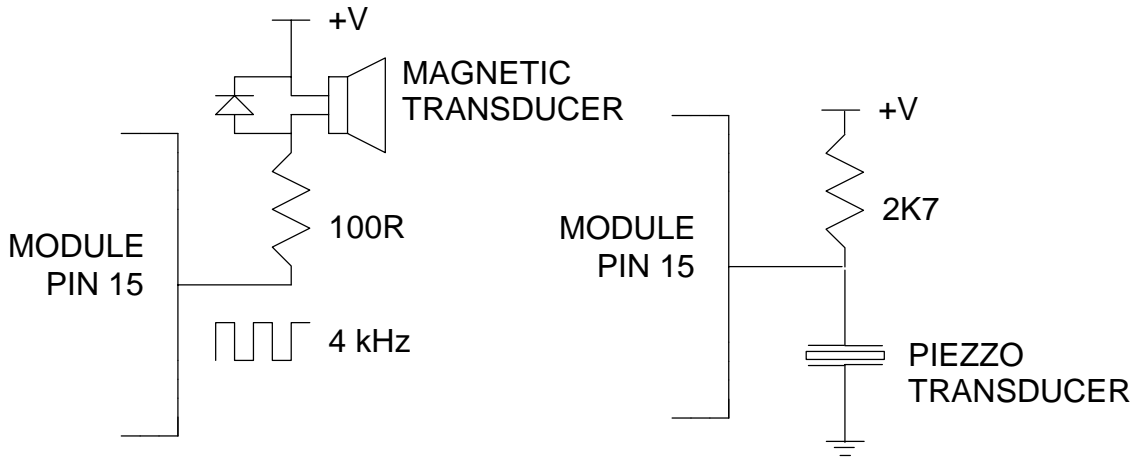

Antenna Connection

The module requires an external antenna. See the application note 'Designing an antenna for the Mifare module' for more information.

Tuning the antenna

The antenna board should have a variable capacitor on it which may need to be adjusted to re-tune the antenna in different environments. To tune the antenna put the module into Tune mode (see output mode selection). Now put a card in the field and adjust the variable capacitor until the unit is beeping repeatedly (beep...beep...beep...beep...). The best tuning is when the gap between beeps is shortest.

INVERT pin

The polarity of DETECT (pin1), CLOCK/DATA0 (pin2) and DATA/DATA1 (pin3) may be inverted by connecting INVERT (pin 5) to 0V.

In most modes the idle level of the signal pins 1,2 and 3 is high. This is acceptable when connecting the module directly to the receiving equipment over a short cable (<15m). However when a long cable exists between module and receiving equipment it is desirable to include an open collector transistor stage between the module and the long cable as shown below:

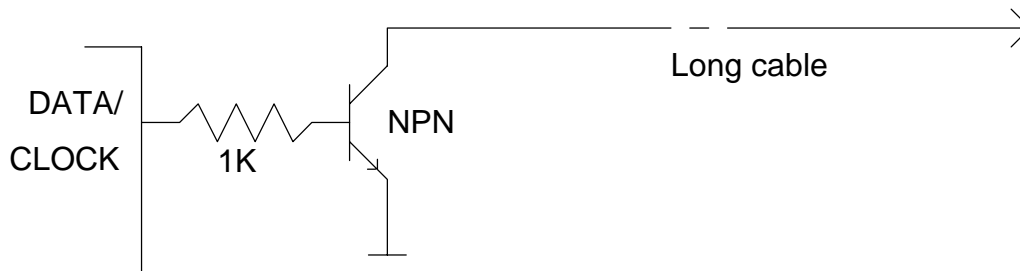

To ensure that the idle state of the transistor is off, the idle level from the module signal pins must be low. To achieve this connect INVERT to 0V.

RS232 (TTL) output mode

The RS232 output from the module is on pin 3 (DATA). This output is suitable to connect directly to the UART of a microprocessor. The idle level is high. The baud rate is 9600. Data format is 8 bits, no parity, and 1 stop bit.

To achieve true RS232 levels the module output should be connected to a level shifter/inverter IC (e.g. MAX232).

The card's ID is output in the following structure:

STX (02h)	DATA (ASCII)	CR (0Dh)	LF (0Ah)	ETX (03h)
-----------	--------------	----------	----------	-----------

The DATA bytes vary according to the number of bits being output:

40 bit mode

DATA = 10 ASCII characters representing the hexadecimal ID number e.g. '0010B2F12A' (30 30 31 30 42 32 46 31 32 41 hex).

32 bit mode

DATA = 10 ASCII characters representing the least significant 32 bits of the tag converted to a decimal number e.g. '0280162602' (30 32 38 30 31 36 32 36 30 32 hex)

24 bit mode

DATA = 8 ASCII characters representing the least significant 24 bits of the tag converted to a decimal number e.g. '11727146' (31 31 37 32 37 31 34 36 hex)

Mag Stripe Modes

In this mode the decimal ID number is clocked out on CLOCK (white wire) and DATA (brown wire) at 100 characters per second. The format is standard as found on Track 2 of a magnetic card:

10 leading 0's	SS	DATA	ES	LRC	5 trailing 0's
----------------	----	------	----	-----	----------------

SS = start sentinel (B hex).

ES = end sentinel (F hex).

LRC = longitudinal redundancy check.

DATA varies according to the number of bits selected:

40 bit mode

DATA = 13 decimal digits with leading zeros. The most significant decimal digit is transmitted first.

32 bit mode

DATA = 10 decimal digits with leading zeros. The most significant decimal digit is transmitted first.

24 bit mode

DATA = 8 decimal digits with leading zeros. The most significant decimal digit is transmitted first.

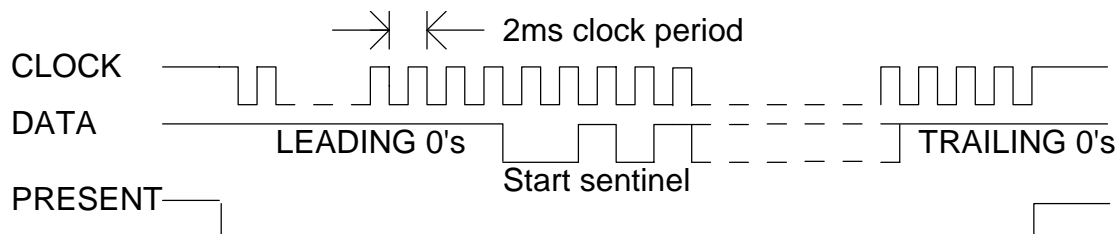

Each character is 5 bits long. The first four bits are the hex digit (0-F) least significant bit first. The fifth bit is an odd parity bit. A 0 is represented by a high level on the DATA wire and a 1 is represented by a low level on the DATA wire. Data is set up on the falling edge of the clock and is stable on the rising edge of the clock. The PRESENT output goes low for the duration of the transmission simulating the CARD PRESENT from a mag card reader.

Fast 40 bit mode

This mode differs from the standard 40bit magstripe mode in the following ways:

- DATA=14 decimal digits with leading zeros.
- The clock period is 200us.
- 10 trailing 0's

All other aspects of this format are the same as the other magstripe formats.

Clock/Data Mode

In this mode all 40 bits of the tag are clocked out with an eight bit header and an eight bit checksum.

Header (11111110)	Data (40 bits)	Checksum
-------------------	----------------	----------

The header is hex FE. The data consists of 40 tag bits sent MSB first. The checksum is a byte addition of the 5 bytes of tag data e.g tag 0010B2F12A has a checksum of $00+10+B2+F1+2A=DD$.

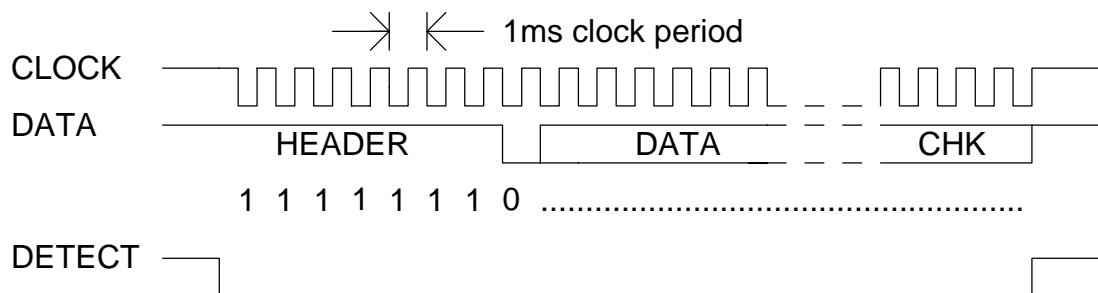

Data is set up on the falling edge of the clock and is stable on the rising edge of the clock.

Wiegand Output Modes

In this mode the tag code is pulsed out on DATA0 (pin 2) and DATA1 (pin 3). Both are normally high. When a tag is presented to the reader 26/34/44 bits are transmitted in the following way:

A binary 1 is represented by a 100 us pulse low on DATA1. A binary 0 is represented by a 100 us pulse low on DATA0. There is a 2 ms inter bit delay.

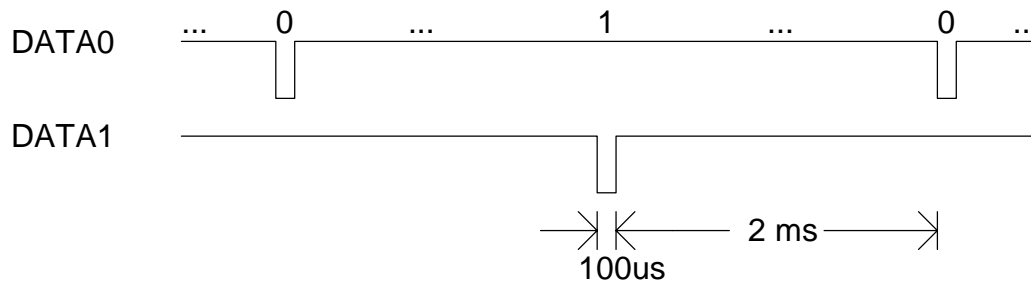

44 bit mode

44 pulses are transmitted:

- The first 8 bits are 0's
- The next 32 bits are the 32 bits of card's ID (MSB first)
- The last 4 bits are the LRC value of the 10 previous nibbles. The LRC is calculated by XORing each nibble. The MSB of the LRC is sent first.

34 bit mode

34 pulses are transmitted:

- The first bit is the even parity of tag bits 9-24.
- The 32 bits of the card's ID (MSB first).
- The last bit is the odd parity of tag bits 25-40.

26 bit mode

26 pulses are transmitted:

- The first bit is the even parity of tag bits 17-28.
- The least significant 24 bits of the card's ID (MSB first).
- The last bit is the odd parity of tag bits 29-40.